

Installation Instructions

INSTRUCTIONS PERTAINING TO A RISK OF FIRE, OR INJURY TO PERSONS.

IMPORTANT SAFETY INSTRUCTIONS. SAVE THESE INSTRUCTIONS.

(Failure to follow the warnings and instructions on this sheet could result in fire, injury, failure of product, and/or voiding of warranty.)

1. Do not touch luminaire while lamp is on. Turn off/unplug and allow to cool before replacing lamp.
2. Lamp gets HOT quickly! Contact only switch/plug when turning on.
3. Do not touch hot lens, body, cap or knuckle.
4. Keep lamp away from materials that may burn.
5. Do not touch lamp at any time. Use a soft cloth. Oil from your skin may damage lamp.
6. Do not operate with damaged or missing parts.
7. Do not disassemble beyond cap removal to facilitate lamp and/or accessory installation or replacement.
8. Remove any debris accumulated in the cap periodically.
9. Do not install within 10 feet of a pool, spa, or fountain.
10. This is a line voltage fixture, use properly rated cable.
11. Have installed in accordance with all applicable installation codes and standards by a person familiar with the construction, operation, and hazards involved.

Notes:

- This fixture should not be mounted in such a way that it is buried or in direct contact with the ground or soil.
- LED models come with push button manual selection of 4 different outputs. See 'Changing LED Output Level' instructions on next page. Output will be set at factory to highest setting, unless otherwise specified when ordered.
- LED models also allow for 100-277V 0-10V dimming (at three highest push button light level settings only) and 120V phase dimming (at highest push button light level setting only). LED models should only be used with compatible dimming systems. Contact Vision3 Lighting for further information.
- All ratings subject to change without notice. See website or contact V3 for most current info.

Caution! Fixture will be hot if lamp is on. Remove power and allow fixture to cool before performing any adjustments or maintenance.

Installation:

Note: The instructions below are for mounting WM2 models with flat plate canopy options, such as the MO3 (shown) or MO15. For models with surface mount canopy options (MO12 or MO13 mounts) refer to the mounts installation instruction for information specific to that mount. All instructions below concerning wiring, box mounting, and safety cable still apply.

1. Unpack the WM2 PAR20 Wall Mount from its shipping container and inspect.
2. Install and wire the Outlet Box (not included) per applicable standards and codes. Note: WM2 models must be used with a 4" Sheet Metal Outlet Box that is mounted to a cross brace or stud in such a way that it will hold the weight of the fixture, as shown in the sketch or similar manner. A 9/32" clearance hole for the Cable Lag Screw should also be drilled in the box before mounting, if one does not already exist, so that the safety cable can be attached to the cross brace or stud. During installation of box, make sure the mount holes for the fixture are oriented as desired.
3. (MO3 & MO15 mounts only) The Universal Mounting Ring must be removed before the luminaire can be mounted to the Outlet Box. Unscrew the two (2) Mount Screws with a 5/32" hex wrench to remove the Universal Mounting Ring.
4. (MO3 & MO15 mounts only) Mount the Universal Mounting Ring to the Outlet Box using appropriately sized Mounting Ring Screws (not supplied). Note: adjust the Universal Mounting Ring so the fixture will be properly oriented when mounted.
5. Use the Cable Lag Screw to mount the Safety Cable to the Cross Brace or stud. Use clearance hole in 4" box mentioned in step 2 above. Note: Safety cable must be lagged to a solid cross brace or stud in a manner capable of holding the weight of the fixture. **Failure to do so may cause injury or death!**
6. Connect the fixtures power leads to the power supply wires (black, white, green to hot, neutral, ground, respectively) using appropriate connectors (not supplied) per applicable codes. Make sure that there is enough slack in the wiring so that the fixture can hang from the safety cable without stressing the wires. Note: Be sure power being supplied matches requirements on Label.

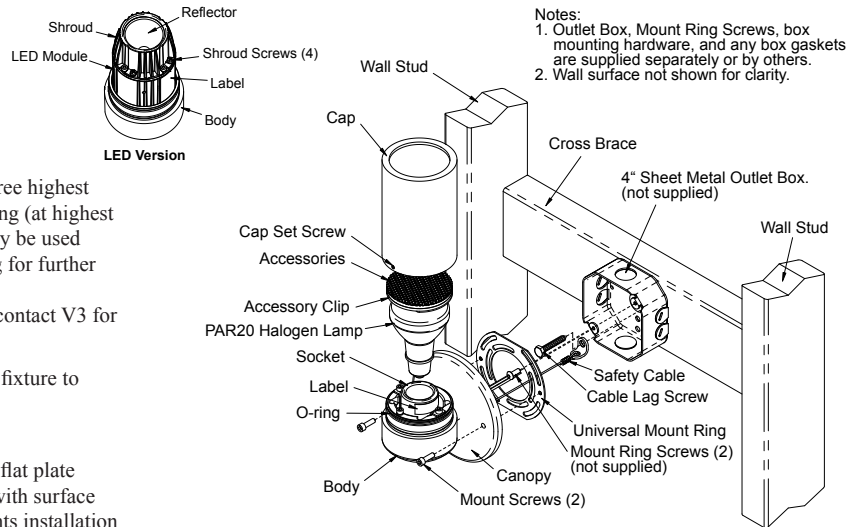

Notes:

1. Outlet Box, Mount Ring Screws, box mounting hardware, and any box gaskets are supplied separately or by others.
2. Wall surface not shown for clarity.

7. Connect the fixtures dimming leads to the dimming control wires using appropriate connectors (not supplied) per applicable codes. Make sure that there is enough slack in the wiring so that the fixture can hang from the safety cable without stressing the wires. The 0-10V(-) control wire (typically gray) should attach to the gray fixture dimming lead. The 0-10V(+) control wire (typically purple) should attach to the fixtures purple dimming lead. If 0-10V dimming is not being used, each of the fixtures dimming leads should be cut and capped separately (connectors not supplied). Note: capping the dimming leads together or allowing them to touch ground may prevent the LED from operating normally. Make sure they are capped separately if not being used.
8. (MO3 & MO15 mounts only) Using the supplied Mount Screws, and a 5/32" hex wrench, mount the WM2 to the Universal Mounting Ring. Note: fixture may be mounted in the up or down position.
9. (MO3 & MO15 mounts only) If the WM2 is not oriented correctly, remove, adjust the Universal Mounting Ring, and re-install.

PAR20 Halogen Lamp Maintenance (for certain models):

1. Remove power from fixture and let cool before touching. **Caution! Luminaire may still be hot!**
2. Loosen the Cap Set Screw using a 3/32" hex tool – do not remove screw!
3. Remove the Cap. Twisting the Cap while removing reduces the risk of damaging the O-ring.
4. Unscrew lamp from Socket and remove. **Caution! Lamp may still be hot! Be sure lamp has cooled before touching.**
5. Clean inside of fixture and cap with a clean dry cloth.
6. Inspect Socket for any damage.
7. Inspect O-ring for damage or dirt. Replace or clean if necessary.
8. Using a soft, clean cloth to hold new Lamp, screw Lamp into Socket. Note: Replacement lamp must not exceed ratings of the luminaire. Read the Label for appropriate lamp type and ratings.

Installation Instructions

INSTRUCTIONS PERTAINING TO A RISK OF FIRE, OR INJURY TO PERSONS.

IMPORTANT SAFETY INSTRUCTIONS. SAVE THESE INSTRUCTIONS.

(Failure to follow the warnings and instructions on this sheet could result in fire, injury, failure of product, and/or voiding of warranty.)

9. Install Cap by pushing and twisting slowly. If O-ring is excessively dry, use a small amount of Krytox lubricant
10. Tighten Cap Set Screw with the 3/32" hex tool so that it just bottoms out. Do not over tighten the Cap Set Screw! This may cause the fixture to not seal properly.

LED Module Maintenance (for certain models):

LED Module Replacement:

While the LED module can be field replaced, it requires complete dis-assembly of the fixture and should only be done for end of life replacement (for changing beam pattern, see 'Changing LED Optics' heading below). Vision3 recommends returning the fixture to the factory for LED module replacement. Contact Vision3 Lighting for instructions on LED module replacement, or to arrange for it to be done at the factory if you are not comfortable doing it.

Changing LED Optics:

To change the beam pattern to something other than what the fixture was specified with, the reflector can be swapped out to a different pattern. These reflectors can be purchased from Vision3 Lighting. To change the reflector:

1. Remove cap as explained in PAR20 Halogen Lamp Maintenance steps 1 thru 4 above.
2. Loosen and remove the four Shroud Screws.
3. Remove the Shroud and the Reflector from the top of the LED module.
4. Set the new Reflector and Shroud on top of the LED Module. The Reflector and Shroud are keyed so that they may only be installed in certain orientations. Make sure any pins / keys line up with their corresponding holes / depressions on the LED module. Do not force or you may damage the Reflector, Shroud, or LED module.
5. Install and tighten the four Shroud Screws. Do not overtighten.
6. Install cap as explained in PAR20 Halogen Lamp Maintenance steps 9 & 10 above.

Changing LED Output Level:

LED module comes with a push button that allows for selection of 4 different outputs. Output will be set at factory to highest setting, unless otherwise specified when ordered. To change the LED output level:

1. Remove cap as explained in PAR20 Halogen Lamp Maintenance steps 1 thru 4 above.
2. Inspect for damage. Replace any damaged parts, if necessary.
3. Clean inside of fixture and Cap with a clean, damp cotton cloth.
4. With fixture powered up, hold down the Output Button for about 4 seconds, until the LED blinks once, and release the button. The LED is now in adjustment mode.
Note: if LED does not enter adjustment mode properly, or does not adjust once in adjustment mode, check to make sure the 0-10V dimming leads are not connected together or grounded.
5. Immediately start pushing the Output Button to cycle thru the different power modes (one button push will advance one power mode). Note: Don't wait too long between button pushes. The LED will revert back to normal mode if the Output Button is not pushed for about 4 seconds when LED is in adjustment mode.
6. When the desired power mode is found, stop pushing the Output Button. When the Output Button is not pushed for about 4 seconds while in adjustment mode, the LED will blink twice, indicating that the LED is back in normal mode.
7. To continue adjusting the output mode, go back to step 4 and repeat the process.
8. Install cap as explained in PAR20 Halogen Lamp Maintenance steps 9 & 10 above.

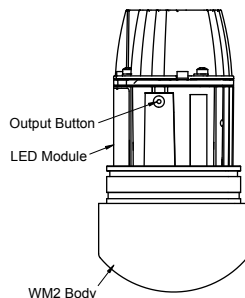

Accessory Maintenance:

1. Remove cap as explained in PAR20 Halogen Lamp Maintenance steps 1 thru 4 above.
2. Remove Accessory Clip from Cap.
3. Carefully remove Accessories from Cap, if any.
4. Inspect Cap, Accessories, and Clip for damage. Replace if necessary.
5. Clean Cap and Accessories with a clean, damp cotton cloth.
6. Carefully install new Accessories into Cap (Cap may hold up to 3 Accessories).
7. Compress Clip and push into Cap until it holds Accessories tightly in Cap.
8. Install cap as explained in PAR20 Halogen Lamp Maintenance steps 9 & 10 above.

Cutoff Shroud Maintenance (square models only):

Square versions of the WM2 come with a Cutoff Shroud that allows for 360° flow-thru water drainage without any light leak on the wall. The Cutoff Shroud is removable for easy debris removal and lens cleaning, and field interchangeable (alternate shrouds available for purchase separately). For Cutoff Shroud maintenance:

1. Loosen the Shroud Set Screw using a 3/32" hex wrench. Set screw does not need to be full removed, only loosened enough to free Cutoff Shroud.
2. Remove Cutoff Shroud from Cap.
3. Clean any dirt or debris from the Cap, Cutoff Shroud, and Lens. With Cutoff Shroud removed, the Lens can be easily cleaned with a razor blade.
4. Place the Cutoff Shroud on the Cap so that the Shroud Set Screw is facing the desired side.
5. Making sure that the Cutoff Shroud is fully seated on the Cap, slightly tighten the Shroud Set Screw. Note: Do not overtighten set screw. Tighten just enough to secure the shroud.

