

## Installation Instructions

### INSTRUCTIONS PERTAINING TO A RISK OF FIRE, OR INJURY TO PERSONS.

#### IMPORTANT SAFETY INSTRUCTIONS. SAVE THESE INSTRUCTIONS.

(Failure to follow the warnings and instructions on this sheet could result in fire, injury, failure of product, and/or voiding of warranty.)

1. Do not touch while lamp is on. Turn off/unplug and allow to cool before replacing lamp.
2. Lamp gets HOT quickly! Contact only switch/plug when turning on.
3. Do not touch hot lens, body, cap or mount.
4. Keep lamp away from materials that may burn.
5. Do not touch lamp at any time. Use a soft cloth. Oil from your skin may damage lamp.
6. Do not operate with damaged or missing parts.
7. Do not disassemble beyond cap removal to facilitate lamp and/or accessory installation or replacement.
8. Remove any debris accumulated in the cap periodically.
9. Do not install within 10 feet of a pool, spa, or fountain.
10. Have installed in accordance with all applicable installation codes and standards by a person familiar with the construction, operation, and hazards involved.
11. Consult a qualified electrician to ensure correct branch circuit conductor.
12. Use only cable rated for proper voltage.
13. Do not pull or hang from fixture! Damage or injury may occur.

#### Notes:

- This fixture should not be mounted in such a way that it is buried or in direct contact with the ground or soil.
- This fixture requires a remote transformer or mount option with integral transformer.
- LED models should only be powered and controlled by compatible transformers and control systems. Contact Vision3 Lighting for approved transformer / controls list. Using non-approved transformers / controls could cause the LED to not operate properly or fail.
- Integral LED options come with a High/Low switch. See 'LED Switching' instructions on next page. Switch will be set to 'High' setting at the factory, unless otherwise specified when ordered.
- Use only Vision3 approved Retrofit MR16 LED options and supplied Heatsink Mount, otherwise LED may overheat and fail.
- LED ratings subject to change without notice. See website or contact V3 for most current info.

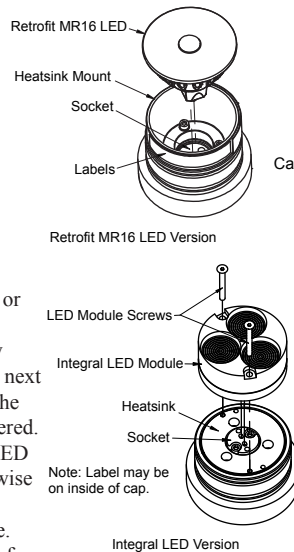

#### Notes:

1. Outlet Box, Mount Ring Screws, box mounting hardware, and any box gaskets are supplied separately or by others.

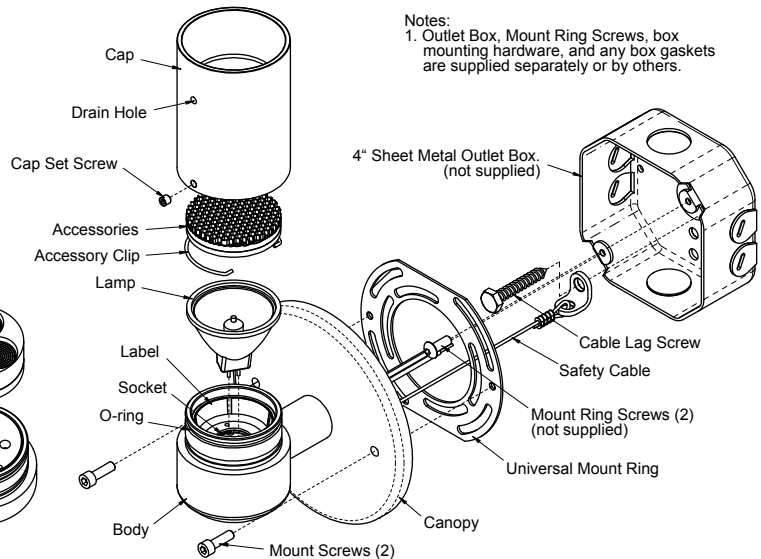

**Caution!** Fixture will be hot if lamp is on. Remove power and allow fixture to cool before performing any adjustments or maintenance.

#### Installation:

The instructions below are for mounting WM1 models with flat plate canopy options, such as the MO3 (shown) or MO15. For models with surface mount canopy options (MO12 mount) refer to the mounts installation instructions for information specific to that mount. All instructions below concerning wiring, box mounting, and safety cable still apply.

1. Unpack the WM1 Wall Mount from its shipping container and inspect.
2. Install and wire the Outlet Box (not included) per applicable standards and codes. Note: Must be used with a 4" Sheet Metal Outlet Box that is mounted to a stud in such a way that it will hold the weight of the fixture. A 9/32" clearance hole for the Cable Lag Screw should also be drilled in the box before mounting, if one does not already exist, so that the safety cable can be attached to the stud.
3. (MO3 & MO15 mounts only) The Universal Mounting Ring must be removed before the WM1 can be mounted to the Outlet Box. Unscrew the two (2) Mount Screws with a 5/32" hex wrench to remove the Universal Mounting Ring.
4. (MO3 & MO15 mounts only) Mount the Universal Mounting Ring to the Outlet Box using appropriately sized Mounting Ring Screws (not supplied). Note: adjust the Universal Mounting Ring so the fixture will be properly oriented when mounted.
5. Use the Cable Lag Screw to mount the Safety Cable to the wall stud. Use clearance hole in 4" box mentioned in step 2 above. Note: Safety cable must be lagged to a solid cross brace or stud in a manner capable of holding the weight of the fixture. **Failure to do so may cause injury or**

#### death!

6. Connect the fixture leads to the power supply wires using appropriate connectors (not supplied) per applicable codes. Make sure that there is enough slack in the wiring so that the fixture can hang from the safety cable without stressing the wires. Note: Be sure power being supplied matches requirements on Label.
7. (MO3 & MO15 mounts only) Using the supplied Mount Screws, and a 5/32" hex wrench, mount the WM1 to the Universal Mounting Ring. Note: fixture may be mounted in the up or down position. Use a liquid thread locker (not supplied) to prevent mounting hardware from becoming loose.
8. (MO3 & MO15 mounts only) If the WM1 is not oriented correctly, remove, adjust the Universal Mounting Ring, and re-install.
9. Install lamp and accessories, if not already installed, as described below.

#### Lamp/LED Module Maintenance:

1. Remove power from fixture and let cool before touching. **Caution! Fixture may still be hot!**
2. Loosen the Cap Set Screw using a 3/32" hex tool – **do not remove screw!**
3. Remove the Cap. Holding the Body and twisting the Cap while removing reduces the risk of damaging the O-ring.
4. Inspect O-ring for damage. Replace if necessary.
5. Replace lamp/LED.

#### For MR16 Halogen Lamp:

- a. Pull lamp straight out. **Caution! Lamp may still be hot! Be sure lamp has cooled before touching.**
- b. Inspect socket for any damage.
- c. Clean inside of fixture and Cap with a clean dry cloth.

## Installation Instructions

### INSTRUCTIONS PERTAINING TO A RISK OF FIRE, OR INJURY TO PERSONS.

### IMPORTANT SAFETY INSTRUCTIONS. SAVE THESE INSTRUCTIONS.

(Failure to follow the warnings and instructions on this sheet could result in fire, injury, failure of product, and/or voiding of warranty.)

- d. Push new lamp straight in, being careful to align pins. **Note:** Replacement lamp must not exceed ratings on Label.

#### For Integral LED Module:

- a. Loosen and remove the LED Module Screws.
- b. Pull LED straight out. Do not twist or the pins will break off in the socket. **Caution! LED may still be hot! Be sure LED has cooled before touching.**
- c. Clean the grease off of the Heatsink top surface using a rag dipped in alcohol.
- d. Inspect the socket for any damage.
- e. If the replacement LED Module does not come with a thermal transfer pad on the base, apply a thin layer of thermal grease (not supplied) to the surface of the Heatsink that will contact the bottom of the LED Module.
- f. Align the pins on the LED Module with the socket and push straight in. Do not twist or push in at an angle or the pins may be damaged.
- g. Install and tighten the LED Module Screws. **Caution!** Over tightening of screws could crack the LED Module case.

#### For Retrofit MR16 LED Lamp:

- a. Pull lamp straight out. **Caution! Lamp may still be hot! Be sure lamp has cooled before touching.**
  - b. Inspect socket for any damage.
  - c. Clean inside of fixture and Cap with a clean dry cloth.
  - d. Push new lamp straight in, being careful to align pins. Make sure Retrofit MR16 Lamp fully contacts Heatsink Mount, otherwise lamp may overheat and fail prematurely. **Note:** Replacement lamp must not exceed ratings on Label. Only use Vision3 approved Retrofit MR16 Lamp and supplied Heatsink Mount, otherwise LED may overheat and fail.
6. Install Cap on fixture by pushing and twisting slowly. If O-ring is excessively dry, use a small amount of Krytox lubricant.
  7. Tighten Cap Set Screw with the 3/32" hex tool so that is just bottoms out. **Do not over tighten the Cap Set Screw!** This may cause the fixture to not seal properly.

#### LED Switching (on certain models):

1. Remove cap as explained in Lamp Maintenance steps 1 thru 4.
2. Inspect for damage. Replace any damaged parts, if necessary.
3. Clean inside of fixture and Cap with a clean, damp cotton cloth.
4. Find LED High/Low Switch on side of Integral LED Module.
5. Using a pin, small nail, etc, flip the switch in the desired direction. See the LED Module Switch sketch for which direction corresponds to which setting.
6. Install cap as explained in Lamp Maintenance steps 6 & 7.

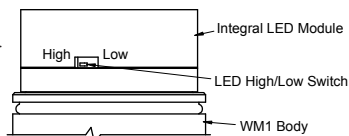

#### Accessory Maintenance:

1. Remove cap as explained in Lamp Maintenance steps 1 thru 4.
2. Remove Accessory Clip from Cap.
3. Carefully remove Accessories from Cap, if any.
4. Inspect Cap, Accessories, and Clip for damage. Replace if necessary.
5. Clean Cap and Accessories with a clean, damp cotton cloth.
6. Carefully install new Accessories into Cap (Cap may hold up to 2 Accessories).
7. Compress Clip and push into Cap until it holds Accessories tightly in Cap.
8. Install cap as explained in Lamp Maintenance steps 6 & 7.

#### Cutoff Shroud Maintenance (square models only):

Square versions of the WM1 come with a Cutoff Shroud that allows for 360° flow-thru water drainage without any light leak on the wall. The Cutoff Shroud is removable for easy debris removal and lens cleaning, and field interchangeable (alternate shrouds available for purchase separately). For Cutoff Shroud maintenance:

1. Loosen the Shroud Set Screw using a 3/32" hex wrench. Set screw does not need to be full removed, only loosened enough to free Cutoff Shroud.
2. Remove Cutoff Shroud from Cap.
3. Clean any dirt or debris from the Cap, Cutoff Shroud, and Lens. With Cutoff Shroud removed, the Lens can be easily cleaned with a razor blade.
4. Place the Cutoff Shroud on the Cap so that the Shroud Set Screw is facing the desired side.
5. Making sure that the Cutoff Shroud is fully seated on the Cap, slightly tighten the Shroud Set Screw. Note: Do not overtighten set screw. Tighten just enough to secure the shroud.

