

## Installation Instructions

### INSTRUCTIONS PERTAINING TO A RISK OF FIRE, OR INJURY TO PERSONS.

#### IMPORTANT SAFETY INSTRUCTIONS. SAVE THESE INSTRUCTIONS.

(Failure to follow the warnings and instructions on this sheet could result in fire, injury, failure of product, and/or voiding of warranty.)

1. Do not touch while lamp is on. Turn off/unplug and allow to cool before replacing lamp.
2. Lamp gets HOT quickly! Contact only switch/plug when turning on.
3. Do not touch hot lens, body, cap or knuckle.
4. Keep lamp away from materials that may burn.
5. Do not touch lamp at any time. Use a soft cloth. Oil from your skin may damage lamp.
6. Do not operate with damaged or missing parts.
7. Do not disassemble beyond cap removal to facilitate lamp and/or accessory installation or replacement.
8. Remove any debris accumulated in the cap periodically.
9. Do not install within 10 feet of a pool, spa, or fountain.
10. Have installed in accordance with all applicable installation codes and standards by a person familiar with the construction, operation, and hazards involved.
11. Consult a qualified electrician to ensure correct branch circuit conductor.
12. For 12V options only use cable rated for low voltage. Cable buried more than 6" must be suitable for direct burial. Direct burial cable may be ordered from Vision3 Lighting.
13. 120-277V line voltage option must use properly rated cable.

#### Installation:

##### Notes:

- This fixture should not be mounted in such a way that it is buried or in direct contact with the ground or soil.
- LED ratings subject to change without notice. See website or contact V3 for most current info.
- (For Amber LED option only) Amber retrofit LED option must follow LED manufacture and wildlife certification program installation & configuration requirements.
- (For Integral LED option only) Integral LED options come with a High/Low switch. See 'LED Switching' instructions. Switch will be set to 'High' setting at the factory, unless otherwise specified when ordered.
- (For Retrofit LED option only) Use only Vision3 approved Retrofit LED options and supplied Heatsink Mount, otherwise LED may overheat and fail.
- (For COB LED w/ Driver option only) COB LED w/ Driver system design should allow an additional 2W per fixture (6W for LE2-0400 & 10W for LE2-0700 or LE2-1000), to reduce system stress during start up.

**Caution!** Fixture will be hot if lamp is on. Remove power and allow fixture to cool before performing any adjustments or maintenance.

1. Install fixture by threading the knuckle into the mount hole of an appropriate mount option. Use supplied O-ring (when used on compatible mount) for water tight installation. Use supplied Lock Nut to secure fixture to mount option. See mount option installation instructions for further installation procedures.
2. Connect the fixtures power leads to the power supply wires using appropriate connectors (not supplied) per applicable codes. Note: Be sure power/ amperage/voltage being supplied matches requirements on Label.
  - a. Halogen/Retrofit MR16 LED/Integral LED Module/Amber LED/COB LED w/ Driver: white fixture leads connect to transformer's secondary/output wiring.
    - 12V model options requires a remote transformer or mount option with integral transformer.
    - 12V models should only be powered and controlled by compatible transformers and control systems. Contact Vision3 Lighting for approved transformer / controls list. Using non-approved transformers / controls could cause the LED to not operate properly or fail.
  - b. COB LED (Remote Driver): red and black leads connect to positive(+) lead (typically red) and negative(-) lead (typically black) from Vision3 Lighting approved LED driver, respectively.
    - 120V-277V COB LED (Remote Driver) fixture options require a remote Vision3 approved driver mount option. Check specification sheet and fixture label for proper rating.
    - 120V-277V COB LED (Remote Driver) option allows for 120-277V 0-10V dimming and 120V phase dimming. Contact Vision3 for further information.

#### Fixture Aiming:

1. Loosen the Vertical Adjustment Screw using a 5/32" hex tool – do not remove screw!
2. Grab fixture Body and push/pull to break grip of tapered knuckle lock.
3. Slightly tighten Vertical Adjustment Screw, using the 5/32" hex tool, so that fixture holds position when released, but still moves when adjusted.
4. Slightly loosen the Horizontal Adjustment Screw (Available on K2 knuckle option only), using the 5/32" hex tool - do not remove screw!
5. Slightly tighten the Horizontal Adjustment Screw (Available on K2 knuckle option only) so that the fixture can be rotated, but still holds position.
6. Adjust fixture to the desired angle. Do not force the fixture past the natural stops built into the knuckle. Note: Rotate fixture fully in opposite direction if a stop is hit before reaching the desired position.
7. Tighten the adjustment screws using the 5/32" hex tool until the knuckle is locked and the fixture no longer moves. Do not over tighten! Tapered knuckle lock requires very little tightening to ensure fixture is locked in position.
8. Adjust cap so that Drain Hole, if any, is oriented at the lowest point allowable. See 'Cap Removal / Installation' procedure below on how to loosen and tighten cap.

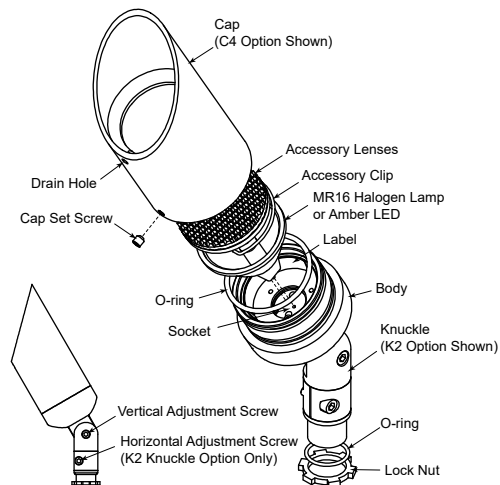

#### Cap Removal / Installation:

##### Cap Removal:

1. Remove power from fixture and let cool before touching. **Caution!** Fixture may still be hot!
2. Loosen the Cap Set Screw using a 3/32" hex tool – **do not remove screw!**
3. Remove the Cap. Holding the Body and twisting the Cap while removing reduces the risk of damaging the O-ring.
4. Inspect O-ring for damage. Replace if necessary.

## Installation Instructions

### INSTRUCTIONS PERTAINING TO A RISK OF FIRE, OR INJURY TO PERSONS.

### IMPORTANT SAFETY INSTRUCTIONS. SAVE THESE INSTRUCTIONS.

(Failure to follow the warnings and instructions on this sheet could result in fire, injury, failure of product, and/or voiding of warranty.)

#### Cap Installation:

1. Install Cap on fixture by pushing and twisting slowly. If O-ring is excessively dry, use a small amount of Krytox lubricant.
2. Tighten Cap Set Screw with the 3/32" hex tool so that it just bottoms out.  
**Do not over tighten the Cap Set Screw!** This may cause the fixture to not seal properly.

#### Accessory Maintenance:

1. Remove Cap as explained in Cap Removal process.
2. Remove Accessory Clip from Cap.
3. Carefully remove Accessories from Cap, if any.
4. Inspect Cap, Accessories, and Clip for damage. Replace if necessary.
5. Clean Cap and Accessories with a clean, damp cotton cloth.
6. Carefully install new Accessories into Cap (Up to 2 Accessories).
7. Compress Clip and push into Cap until it holds Accessories tightly in Cap.
8. Install Cap as explained in Cap Installation process.

#### MR16 Halogen Lamp & Amber LED Maintenance (for certain models):

1. Remove Cap as explained in Cap Removal process.
2. Pull lamp straight out. **Caution! Lamp may still be hot! Be sure lamp has cooled before touching.**
3. Inspect socket for any damage.
4. Clean inside of fixture and Cap with a clean dry cloth.
5. Push new lamp straight in, being careful to align pins. **Note:** Replacement lamp must not exceed ratings on Label.
6. Install Cap as explained in Cap Installation process.

#### Integral LED Module Maintenance (for certain models):

##### Integral LED Module Replacement:

1. Remove Cap as explained in Cap Removal process.
2. Loosen and remove the LED Module Screws.
3. Pull LED straight out. Do not twist or the pins will break off in the socket. **Caution! LED may still be hot! Be sure LED has cooled before touching.**
4. Clean the grease off of the Heatsink top surface using a rag dipped in alcohol.
5. Inspect the socket for any damage.
6. If the replacement LED Module does not come with a thermal transfer pad on the base, apply a thin layer of thermal grease (not supplied) to the surface of the Heatsink that will contact the bottom of the LED Module.
7. Align the pins on the LED Module with the socket and push straight in. Do not twist or push in at an angle or the pins may be damaged.
8. Install and tighten the LED Module Screws. **Caution!** Over tightening of screws could crack the LED Module case.
9. Install Cap as explained in Cap Installation process.

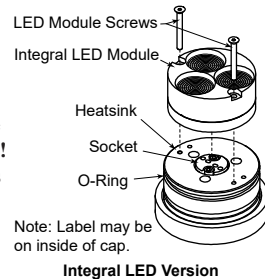

##### Integral LED Output Switching:

1. Remove Cap as explained in Cap Removal process.
2. Inspect for damage. Replace any damaged parts, if necessary.
3. Clean inside of fixture and Cap with a clean, damp cotton cloth.
4. Find LED High/Low Switch on side of Integral LED Module.
5. Using a pin, small nail, etc, flip the switch in the desired direction. See the LED Module Switch sketch for which direction corresponds to which setting.
6. Install Cap as explained in Cap Installation process.

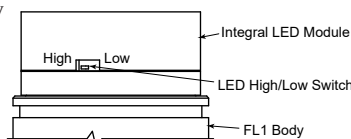

#### Retrofit MR16 LED Maintenance (for certain models):

1. Remove Cap as explained in Cap Removal process.

2. Pull lamp straight out. **Caution! Lamp may still be hot! Be sure lamp has cooled before touching.**
3. Inspect socket for any damage.
4. Clean inside of fixture and Cap with a clean dry cloth.
5. Push new lamp straight in, being careful to align pins. Make sure Retrofit MR16 Lamp fully contacts Heatsink Mount, otherwise lamp may overheat and fail prematurely. **Note:** Replacement lamp must not exceed ratings on Label. Only use Vision3 approved Retrofit MR16 Lamp and supplied Heatsink Mount, otherwise LED may overheat and fail.
6. Install Cap as explained in Cap Installation process.

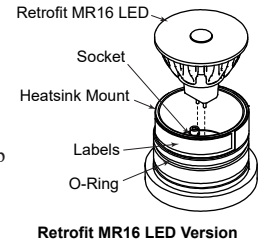

#### COB LED & Driver Maintenance (for certain models):

##### Changing Optics:

1. Remove Cap as explained in Cap Removal process.
2. Twist Reflector counter-clockwise to unlock and remove.
3. Insert new Reflector and twist clockwise to lock.
4. Install Cap as explained in Cap Installation process.

##### Changing COB Chip:

1. Remove Cap as explained in Cap Removal process.
2. Twist Reflector counter-clockwise to unlock and remove.
3. Loosen and remove the two Holder Screws, the Reflector Adapter, and the Holder. **Note:** Twist Holder to facilitate COB removal.
4. Note the orientation of the COB. Compress the Holder clip and carefully remove the COB chip.
5. Thoroughly clean the COB Mount with a lint free towel. **Note:** Make sure the old Thermal Pad and any residue are removed from the COB Mount.
6. Place the new COB up against the Holder clip in the same orientation as the removed COB. Ensure that the polarity marks on the Holder match the polarity marks on the COB. Slowly press on the opposite side of COB to compress the Holder clip until the COB drops into the recess. **Note:** Only touch the edges of the COB as oils and dirt from your skin can damage the diodes.
7. Remove clear plastic film from supplied Thermal Pad, and, using light pressure, apply to back of the new COB chip. Make sure pad is square and fully covers the back of the COB. Remove secondary clear plastic film from the exposed side of the Thermal Pad.
8. Place the Holder and Reflector Adapter on the COB Mount in the same orientation as it was removed.
9. Install and tighten the two Holder Screws. Do not overtighten.
10. Insert Reflector and twist clockwise to lock.
11. Install Cap as explained in Cap Installation process.

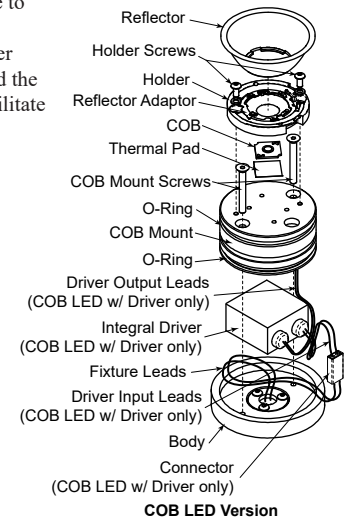

##### Changing COB LED Integral Driver (COB LED w/ Driver only):

1. Remove Cap as explained in Cap Removal process.
2. Twist Reflector counter-clockwise to unlock and remove.
3. Lightly pull and twist Driver Output Leads (red & blue) until they are removed from the Holder. **Note:** lead position.

## Installation Instructions

### INSTRUCTIONS PERTAINING TO A RISK OF FIRE, OR INJURY TO PERSONS.

#### IMPORTANT SAFETY INSTRUCTIONS. SAVE THESE INSTRUCTIONS.

(Failure to follow the warnings and instructions on this sheet could result in fire, injury, failure of product, and/or voiding of warranty.)

4. Loosen and remove the two Holder Screws, the Reflector Adapter, and the Holder. Note: Twist Holder to facilitate COB removal.
5. Loosen and remove the two COB Mount Screws.
6. Note the orientation of the COB Mount. Remove the COB Mount by slowly pulling it off of the body.
7. Note positioning and routing of Integral Driver wires. Remove Integral Driver from the COB Mount.
8. Lightly pull and twist Driver Input Leads (black) to remove from Connector.
9. Install new Integral Driver by inserting input leads (black) into Connector. Route Integral Driver leads similarly as the removed Integral Driver.
10. Route the Driver Output Leads (red & blue) through the COB Mount and then seat the Integral Driver in the COB Mount.
11. Install COB Mount onto the Body in the same orientation as it was removed.
12. Install and tighten the two COB Mount Screws until the COB Mount bottoms out. **Caution! Do not pinch leads!**
13. Place the Holder with COB and Reflector Adapter on the COB Mount in the same orientation as it was removed. Note: If COB chip needs to be replaced also, do that now, as explained above.
14. Install and evenly tighten the two Holder Screws. Do not overtighten.
15. Install Driver Output Leads into the Holder (red to '+' & blue to '-'). Excess wire can be pushed into COB Mount.
16. Insert Reflector and twist clockwise to lock.
17. Install Cap as explained in Cap Installation process.

#### Cutoff Shroud Maintenance (square models only):

Square versions of the FL1 come with a Cutoff Shroud that allows for 360° flow-thru water drainage without any light leak. The Cutoff Shroud is removable for easy debris removal and lens cleaning, and field interchangeable (alternate shrouds available for purchase separately). For Cutoff Shroud maintenance:

1. Loosen the Shroud Set Screw using a 3/32" hex wrench. Set screw does not need to be fully removed, only loosened enough to free Cutoff Shroud.
2. Remove Cutoff Shroud from Cap.
3. Clean any dirt or debris from the Cap, Cutoff Shroud, and Lens. With Cutoff Shroud removed, the Lens can be easily cleaned with a razor blade.
4. Place the Cutoff Shroud on the Cap so that the Shroud Set Screw is facing the desired side.
5. Making sure that the Cutoff Shroud is fully seated on the Cap, slightly tighten the Shroud Set Screw. Note: Do not overtighten set screw. Tighten just enough to secure the shroud.

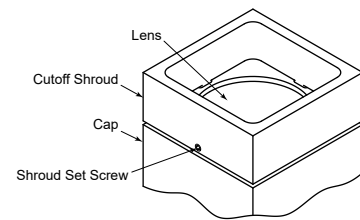

Available Cutoff Shroud Options:

